

## SMALL USB CARBON DIOXIDE (CO<sub>2</sub>) SENSOR

## DXC120



### DESCRIPTION

The DXC120 is a small USB-connected gas sensor for monitoring the indoor level of carbon dioxide (CO<sub>2</sub>). Built around an advanced NDIR CO<sub>2</sub> sensor, it provides years of precise gas level. The DXC120 has been specifically designed to meet the needs of monitoring CO<sub>2</sub> levels in living places such as home, workplace, or other environments with moderate ambient conditions.

### APPLICATIONS

- Research & development
- Robotics
- Home air quality monitoring<sup>[1]</sup>
- OEM integration
- Server rooms
- Building automation
- Workplace
- Public spaces
- Transport station
- Warehouses
- Manufacturing facilities
- Engineering

### INSTALLATION TIME

Less than 3 minutes

### UNIQUE SERIAL NUMBER

Each unit is assigned a unique serial number allowing for traceability and certification

### FREE DAQ SOFTWARE

Real-time data visualization and logging

### DATA INTEGRATION

Command-line tools for direct data access and integration

### OPTIONS

Virtual COM Port (VCP) communication protocol

### ALSO AVAILABLE

Traceability certificates

### SPECIFICATIONS

Parameter	Condition	Value	Units
<b>Carbon dioxide</b>			
CO <sub>2</sub> detection range	Typ.	400 to 10 000	ppm
Accuracy <sup>[2]</sup>	Typ.	±(30 ppm + 3%)	ppm
ADC resolution	–	24	bits
Accuracy drift <sup>[1]</sup>	Over lifetime, 400 to 10,000 ppm	± 50	ppm
Sensor lifetime	Operating conditions	15	years
Repeatability <sup>[3]</sup>	400 to 10,000 ppm	± 10	ppm
Temperature stability <sup>[4]</sup>	0 to 50°C	2.5	ppm/°C
Samples rate	–	1	s
Response time <sup>[5]</sup>	t63%	25	s
Factory calibrated <sup>[6]</sup>	Individually	Yes	–
Calibration baseline	Ambient air, >400 ppm	≈420	ppm
Number of IR channel	–	2	ch

### SPECIFICATIONS

Parameter	Condition	Value	Units
<b>Power supply</b>			
Voltage	Powered through a USB port	5	V
Current Consumption	At 5V	≈30	mA
Current Consumption	Peak, 0.5s	85	mA
<b>Mechanical</b>			
Dimensions	See schema below	–	–
Colour	Cyan	–	–
Weight	Without cable	21	g
<b>Housing</b>			
Operating temperature	–	0 to 50 <sup>[8]</sup>	°C
Operating relative humidity	Non-condensing	10 to 90	%RH
Material	ABS plastic		
IP rating	–	51 <sup>[7]</sup>	–
<b>Miscellaneous</b>			
Fully linearized	–	Yes	–
Sensors technology	–	NDIR	–
Long-term stability	–	Yes	–
Temperature compensated	–	Yes	–

<sup>[2]</sup> Deviation to a high-precision reference in the calibrated range (400 - 10,000 ppm) of the sensor.

<sup>[3]</sup> RMS error of consecutive measurements at constant conditions.

<sup>[4]</sup> Average slope of CO<sub>2</sub> accuracy when changing temperature, valid at 400 ppm.

<sup>[5]</sup> Time for achieving 63% of a respective step function. Response time depends on design-in, heat exchange and environment of the sensor in the final application.

<sup>[6]</sup> Each sensor is individually calibrated by Dracal Technologies and ready to use prior to shipping.

<sup>[7]</sup> If water condensation or splashing is possible, protect the sensor and cable converter using extra precautions. Extra housing may be required depending on the application.

<sup>[8]</sup> Exposing the DXC100 at T > 50°C might result in permanent damage.

<sup>[9]</sup> In a fully controlled environment.

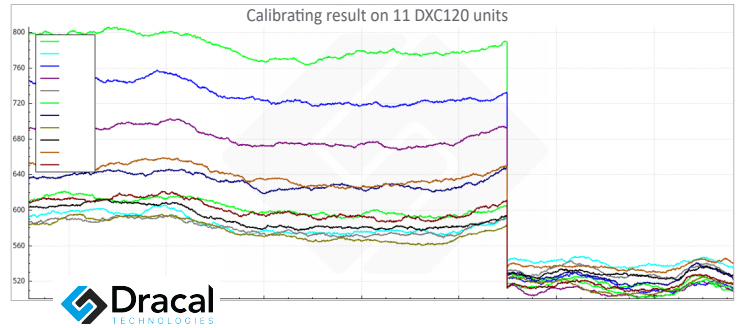
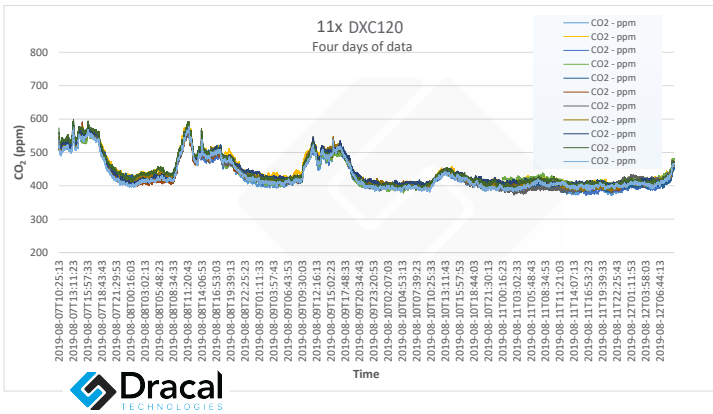

**AVAILABLE CHANNEL(S)**  
As displayed in our logging software

CHANNEL ID*	DESCRIPTION	TYPE	NATURE
00	SDC30 CO2 GAS PPM	CO2 Gas PPM	Real

\* Channel Id as it appears in QTenki. Virtual channel Id differs in QTenki and usbtkeniget.

**PRODUCT DIMENSIONS**

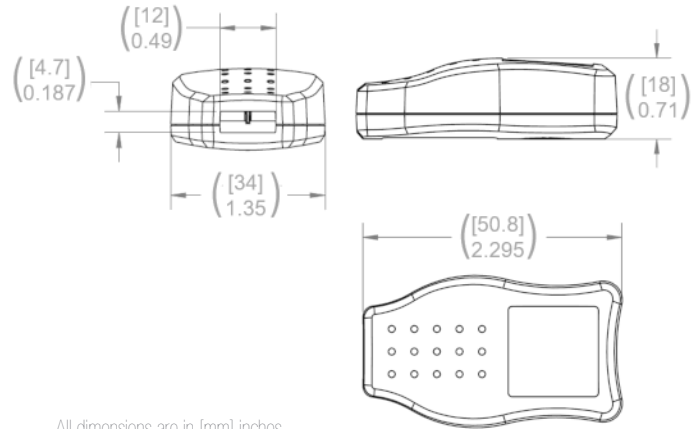

All dimensions are in [mm] inches

**WARNING:** Keep in mind that electromagnetic interferences (EMI) may adversely reduce the precision of the sensor. Avoid using this unit close to EMI sources such as or, transformers, high voltage and fluorescent light.

**WARNING:** Do not install the sensor on a flat surface (table, bench, etc.).

**NOTE:** This product is not waterproof and must be protected if contact with water is possible.

If the probe is inadvertently splashed or submerged in water for a few seconds, unplug the unit, shake it up and let it dry.

**TIP:** Avoid installing the sensor in a location where considerable vibrations may be present. Large vibrations can introduce extra inaccuracy in the pressure readings.

**TIP:** Do not plug the sensor directly into a USB port of a computer. The heat and air from the computer will affect the measurements of the sensor. Use, at least, a short USB extension cable (provided).

**TIP:** The sensor will perform better when installed on a wall (vertically), with the USB cable downward.

**Warning:** This product is not designed for use in, and should not be used for, human applications.

**Note:** While every effort has been made to ensure accuracy in this publication, no responsibility can be accepted for errors or omissions.

**Note:** Data may change without notification, and you are strongly advised to obtain copies of the most recently issued datasheet.

**ORDERING**

PRODUCT(S)		
PART NUMBER	OPTION	DESCRIPTION
601082	USB-DXC120	USB Carbon dioxide (CO2) gas sensor
603082	VCP-DXC120	USB Carbon dioxide (CO2) gas sensor - with VCP mode

Sales:  
[sales@dracal.com](mailto:sales@dracal.com)

General Inquiries:  
[info@dracal.com](mailto:info@dracal.com)

Technical Support:  
[support@dracal.com](mailto:support@dracal.com)

Visit us at:  
[www.dracal.com](http://www.dracal.com)

Dracal Technologies Inc.  
7900 boul. Taschereau  
Edifice A, suite 204  
Brossard, QC, Canada  
J4X 1C2