

2/3 WIRE RTD SENSOR TO USB ADAPTER

RTD200



DESCRIPTION

Designed to measure 100 ohm Pt100 RTD probes, this device provides accurate temperature measurements using a 2 or 3 wire sensor. The sensors are connected using a standard 3-pin mini RTD connector. In 3-wire mode, the RTD200 will correct the measured value taking into account the errors introduced by the length of the probe cable. The compact USB-key form factor simplifies integration even in space-constrained applications. The *-CAL* option allows the instrument to be calibrated on up to 3 points for greater accuracy. The *VCP*-option allows the user to communicate with the instrument in virtual COM port mode.

APPLICATIONS

- Research & development
- Environmental chamber
- Pre-certification
- Server rooms
- Building automation
- Green house
- Manufacturing
- Engineering

INSTALLATION TIME

Less than 10 minutes

UNIQUE SERIAL NUMBER

Each unit is assigned a unique serial number allowing for traceability and certification

FREE DAQ SOFTWARE

Real-time data visualization and logging

DATA INTEGRATION

Command-line tools for direct data access and integration

OPTIONS

Virtual COM Port (VCP) communication protocol

3-point user calibration mechanism

ALSO AVAILABLE

Traceability certificates

SPECIFICATIONS			
Parameter	Condition	Value	Units
Temperature			
Unit operating range	Probe dependant	- 200 to 800	°C
ADC resolution	–	18	bits
Temperature resolution	Typ.	0.02	°C
Accuracy	Typ., at 25°C Excluding probe	±0.06	°C
Response time	t63%	Probe dependant	
Sensing element type	RTD	100	Ohms
Samples rate	Up to 3 SPS	250	mS
Factory calibrated	Individually ^[2]	Yes	–
Calibration value point	–	0.000	°C
Pre-wired PT100 probe available	Yes	See image below	–

SPECIFICATIONS			
Parameter	Condition	Value	Units
Power supply			
Voltage	Powered through a USB port	5	V
Current Consumption	At 5V	≈19	mA
Mechanical			
Dimensions	See schema below	–	–
Colour	Cyan	–	–
Weight	Without USB cable	25	g
Housing and USB cable			
Operating temperature	–	-20 to 70	°C
Operating relative humidity	Non-condensing	10 to 90	
Material	ABS plastic		
IP rating	–	51 ^[3]	–
System galvanic isolation	–	None	–
Miscellaneous			
Connection	Polarized 3-pin standard ^[1] miniature receptacle		
Long-term stability	–	Yes	–
Temperature compensated	–	Yes	–

^[1] Not all pre-wired probes are wired the same and may require wiring re-arrangement in its connector.

^[2] Each sensor is individually calibrated by Dracal technologies and their correction coefficients are stored in each of them.

^[3] If water condensation is possible, it is recommended to install the probe pointing down to reduce the risk of water build-up in the sensor. If water splashing is possible, protect the sensor and cable converter using extra precautions. Extra housing may be required depending on the application.

RTD200 WITH OUR OPTIONAL PROBE (RTD-PT100_SIL_A)



PROBE WIRING OPTIONS

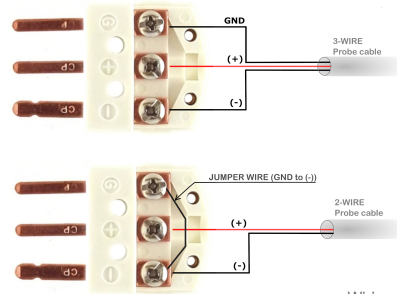

Wiring for RTD200 only

PRODUCT DIMENSIONS

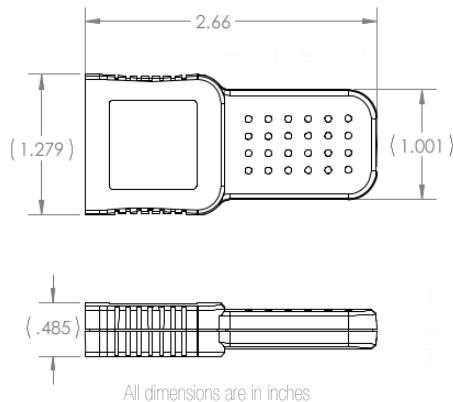

AVAILABLE CHANNEL(S)

As displayed in our logging software

CHANNEL ID*	DESCRIPTION	TYPE	NATURE
00	PT100 Temperature sensor	Temperature	Real

* Channel Id as it appears in DracalView. Virtual channel Id differ in DracaView and usbtenkiget.

CAUTION: Keep in mind that electromagnetic interferences (EMI) may adversely reduce the precision of the sensor. Avoid using this unit close to EMI sources such as, transformers, high voltage and fluorescent light.

TIP: Note that this product is not waterproof and must be protected if contact with water is possible.

TIP: Avoid installing the sensor in a location where considerable vibrations may be present. Large vibrations can introduce extra inaccuracy in the pressure readings.

ORDERING

PRODUCT(S)

PART NUMBER	OPTION	DESCRIPTION
601046	USB-RTD200	2/3 Wire RTD sensor to USB adapter
603046	VCP-RTD200	2/3 Wire RTD sensor to USB adapter - with VCP mode
608046	USB-RTD200-CAL	2/3 Wire RTD sensor to USB adapter - calibratable
601108	RTD-PT100_SIL_A	RTD probe for the RTD200 (sold separately)

TRACEABILITY CERTIFICATE(S)

NT1WT	1-point temperature certificate for one (1) unit
NT2WT	2-point temperature certificate for one (1) unit
NT3WT	3-point temperature certificate for one (1) unit

Warning: This product is not designed for use in, and should not be used for, human applications.

Note: While every effort has been made to ensure accuracy in this publication, no responsibility can be accepted for errors or omissions.

Note: Data may change without notification, and you are strongly advised to obtain copies of the most recently issued datasheet.

Sales:
sales@dracal.com

General Inquiries:
info@dracal.com

Technical Support:
support@dracal.com

Visit us at:
www.dracal.com

Dracal Technologies Inc.
7900 boul. Taschereau
Édifice A, suite 204
Brossard, QC, Canada
J4X 1C2